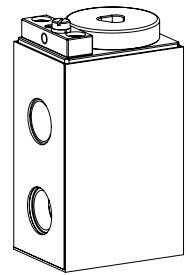

Solenoid coil MKY45/18x60
For explosion-hazard zones
Protection class IP65/66/67
Surface AISI 316L
Optional with integrated amplifier electronics

Ex db IIC T6, T4 Gb
Ex tb IIIC T80°C, T130°C Db
Ex db I Mb
 Ⓔ**x** II 2 G Ex db IIC T6, T4
 Ⓔ**x** II 2 D Ex tb IIIC T80°C, T130°C
 Ⓔ**x** I M2 Ex db I Mb
Class I, Division I, Group A, B, C, D T4
Class II & III, Division I, Group E, F, G T4

DESCRIPTION

For explosion-hazard zones
 Solenoid coil for explosion-hazard zones.
 The flameproof enclosure prevents an explosion in the interior from getting outside.
 The design prevents a surface temperature capable of igniting. The steel housing is AISI 316L. The optional amplifier electronics have an analogue interface and can be adjusted by means of push-buttons and 7 segment display or by means of the parameterisation software PASO.

FUNCTION

In combination with an armature tube, the function of a switching solenoid or of a proportional solenoid results. Solenoid coils in AC - construction have an integrated rectifier. All cable threaded joints certified for this explosion protection class with a protection class of at least IP65 can be used.

APPLICATION

The solenoid coil is suitable for use in all explosion-hazard zones, open cast and also in mines.

This signifies, that the coils are certified for applications in zones with explosion-hazard gas, steam, vapour, air and dust mixtures of the zones 1/21 and 2/22.

Valves for explosion-hazard zones are utilised in:

- the shipping- and offshore industries
- the oil- and gas industries
- the chemical industry
- wood processing
- grain mills
- the mining application

CERTIFICATES

in accordance with	Surface gas and dust				Mining
	Standard -25 °C to...	M224 -40 °C to...	M238 -60 °C to...	Amplifier M248	
ATEX / UKEX	x	x	x	x	x
IECEX	x	x	x	x	x
USA / CANADA	x	x	x	x	
EAC (GOST Ex)	x	x	x	x	x
CCC	x	x	x	x	x
PESO	x	x	x		

The certificates can be found on www.wandfluh.com / Accompanying Ex-proof / MKY45/18-...-L...

TYPE CODE

M K Y 45 / 18 x 60 - / / - K9 - #

Mobile execution, metal housing

Terminal box without cable

Explosion proof version Ex d

Housing width 45 mm

Internal coil diameter 18 mm

Coil length 60 mm

Nominal voltage U_N 12 VDC **G12** 115 VAC **R115**
 24 VDC **G24** 230 VAC **R230**

Nominal power U_N 6 W **L6** 9 W **L9** 15 W **L15** 21 W **L21**

Certificates ATEX, IECEX, CCC, EAC, PESO USA / Canada **UC** (without M254)

Surface protection

Temperature range -25 °C bis ...
 -40 °C bis ... **M224**
 -60 °C bis ... **M238**

Function Amplifier **M248** only G12 or G24 / up to max. L15 not for M224 and M238
 Freewheel diode **M256** do not use for proportional functions
 Bipolar protecting diode **M264** only G24
 Power reduction **M272** only L6

Design-Index (Subject to change)

DIMENSIONS

without amplifier electronics

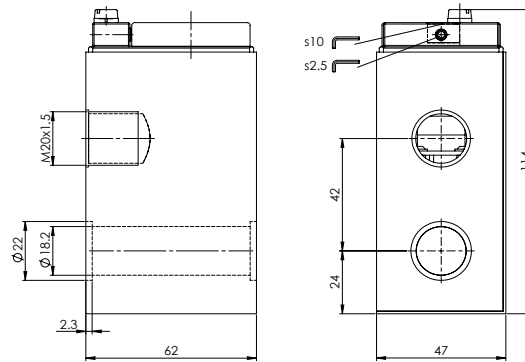
CHARACTERISTICS

Coil winding isolation class	H
Protection class acc. to EN 60529	IP65/66/67, with corresponding cable gland and correct installation
Relative duty factor	100 % DF, combined with armature tube and valve
Reference temperature	Execution L6 / L9: -25...+40 °C (operation as T1...T6/T80 °C) -25...+90 °C (operation as T1...T4/T130 °C) Execution L15: Temperature range „-25° to ...“ -25...+70 °C (operation as T1...T4/T130 °C) Temperature range „-40° to ...“ -40...+70 °C (operation as T1...T4/T130 °C) Temperature range „-60° to ...“ -60...+70 °C (operation as T1...T4/T130 °C)
Housing	Execution L 21: -25...+60 °C (operation as T1...T4/T130 °C) Steel housing AISI 316L
Relative humidity factor	max. 95 % (not dew-forming)
Corrosion protection	Salt spray test in accordance with EN ISO 9227 > = 2000 hours
Maximum operating voltage	Nominal voltage +10 %
Nominal frequency	in acc. with name plate ±2 %
Standard nominal voltages	U _N = 12 VDC U _N = 24 VDC U _N = 115 VAC U _N = 230 VAC Other nominal voltages in the ranges of 12–230 VDC and 24–230 VAC on request

For further details see installation and operating instructions no. 990.8001.

Standard nominal powers

P _N = 6 W	with M272	P _R = 3,8 W
P _N = 9 W		
P _N = 15 W		
P _N = 21 W		

	12 VDC			
Nominal power (W)	6	9	15	21
Nominal resistance (Ω)	24,75	18,5	9,9	7,1
Minimum resistance	24	18	9,6	6,9
Recommended rated current for fuse inserts (mA)	1000	1600	2500	4000
Limiting current (mA) (Proportional function)	400	610	960	1230
	24 VDC			
Nominal power (W)	6	9	15	21
Nominal resistance (Ω)	98,5	65,7	39,4	29
Minimum resistance	96	64,1	38,5	28,2
Recommended rated current for fuse inserts (mA)	400	800	1250	2000
Limiting current (mA) (Proportional function)	200	300	450	600
	115 VAC			
Nominal power (W)	6	9	15	21
Nominal resistance (Ω)	1840	1390	720	517
Minimaler Widerstand	1800	1350	702	502
Recommended rated current for fuse inserts (mA)	100	200	315	400
	230 VAC			
Nominal power (W)	6	9	15	21
Nominal resistance (Ω)	7280	4850	2910	2080
Minimaler Widerstand	7090	4725	2840	2020
Recommended rated current for fuse inserts (mA)	100	100	160	200

 M272 reduces the nominal power (P_N) after 500ms to a reduced power (P_R)
 Values are valid at 20 °C

OPERATION SECURITY

The solenoid coil must only be put into operation, if the requirements of the operating instructions supplied are observed to their full extent.
 In case of non-observance, no liability can be assumed.

A corresponding fuse in accordance with its design current has to be connected in series as short-circuit protection for every solenoid coil.

INSTALLATION

For stack assembly please observe the remarks in the operating instructions.

ACCESSORIES

- The operating instructions incl. the EC declaration of conformity for solenoid coils of the type MKY45/18x60 is supplied in German, English and French (download under www.wandfluh.com)
- Type test certifications (download under www.wandfluh.com)
- EC-declaration of conformity (download under www.wandfluh.com)
- Recognition of production quality assurance
 QAN: SEV ATEX 4130, QAR: CH/SEV/QAR16.0001 (download under www.wandfluh.com)

With amplifier electronics and with analogue interface

Digital amplifier electronics to MKY...M248

- Electronics integrated in solenoid housing
- For proportional or switching valves
- Screw terminals for simple assembly
- 1 analogue input
- 1 digital input
- Adjustable with push-buttons and display directly on the device or via PC

ELECTRICAL SPECIFICATIONS

Supply voltage Residual ripple Fuse No-load current Max. current consumption Analogue input Resolution Input resistance Stabilised output voltage Solenoid current: • Minimal current I_{min} • Maximal current I_{max}	G12: 12 V +10 %, G24: 24 V +10 % < +/-5 % low approx. 20 mA No-load current + limiting current of the solenoid 1 input non-differential Voltage / current (switchable by means of parameter) 0...+/- 10V or 0/4...20mA 10-Bit Voltage input >100 kΩ (Input current < 5 mA) Load for current input = 124 Ω 5 VDC max. load 20 mA Adjustable 0... I_{max} mA Factory setting 30 mA G24/L15 Adjustable I_{min} ...510 mA Factory setting 450 mA G12/L15 Adjustable I_{min} ...1020 mA Factory setting 960 mA	G24/L9 Adjustable I_{min} ...510 mA Factory setting 300 mA G12/L9 Adjustable I_{min} ...685 mA Factory setting 610 mA Frequency adjustable 4...500Hz Factory setting 80Hz Level adjustable 0...400mA Factory setting 150 mA <1% at $\Delta T = 40^\circ C$ 1 input high-active, no pull-up/down Switching threshold high 6...32 VDC Switching threshold low 0...1 VDC Usable as frequency input (frequency 5...5000 Hz) and as PWM input (automatic frequency recognition) Via digital input Requires the Wandfluh USB adapter PD2 EMC Immunity Emission EN 61 000-6-2 EN 61 000-6-4
--	--	--

DIMENSIONS

with amplifier electronics

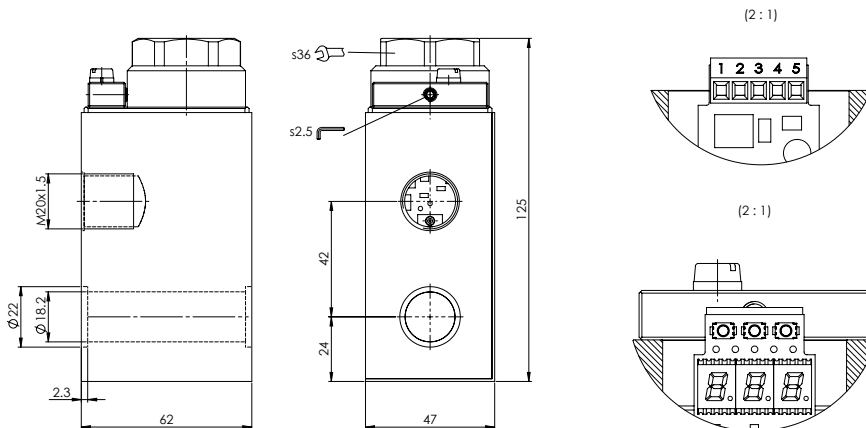

CONNECTOR ASSIGNMENT (X1)

- 1 = + VDC
- 2 = Command value
- 3 = Dig Inp
- 4 = Stab out
- 5 = GND

GENERAL SPECIFICATIONS

Execution	Electronics board built-in directly in solenoid housing
Connections	
Screw terminal	5-pole, max. 1.0 mm ²
USB interface	via connection «Digital Input», requires an additional Wandfluh adapter PD2

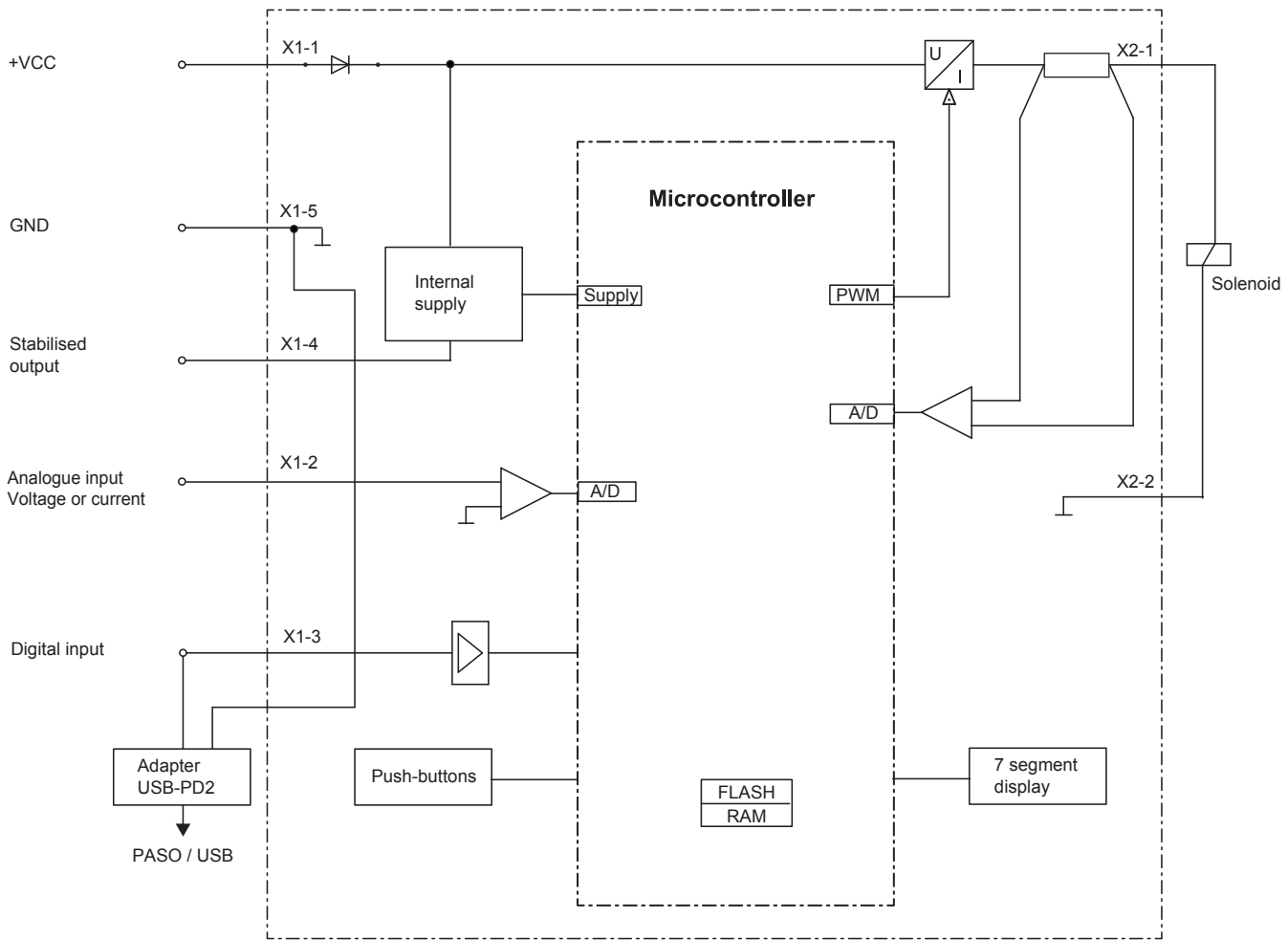
BLOCK DIAGRAM



START-UP

Information regarding installation and commissioning are contained in the information leaflet supplied with the amplifier electronics and in the operating instructions.

Additional information can be found on our website:
«www.wandfluh.com»

Free-of-charge download:

- «PASO-PD2» Parameterisation software
- Operating instruction (*.pdf)

ADDITIONAL INFORMATION

Proportional spool valve	Wandfluh documentation register	1.10
Proportional pressure valves	register	2.3
Proportional flow control valves	register	2.6

ACCESSORIES

USB adapter PD2 incl. USB cable, 1,8 m (for parameterisation via PASO)	Article no. 726.9900
--	----------------------

PARAMETER SETTINGS

The MKY electronics have push-buttons and a display which enable setting the most important parameters. In addition, the digital input can be used as a communication interface, through which, by means of the parameterisation software "PASO-PD2", the complete parameterisation and diagnostics can be carried out. For this, the Wandfluh USB-PD2 adapter is required.

Attention: During the communication, the digital input cannot be used.

FUNCTION DESCRIPTION

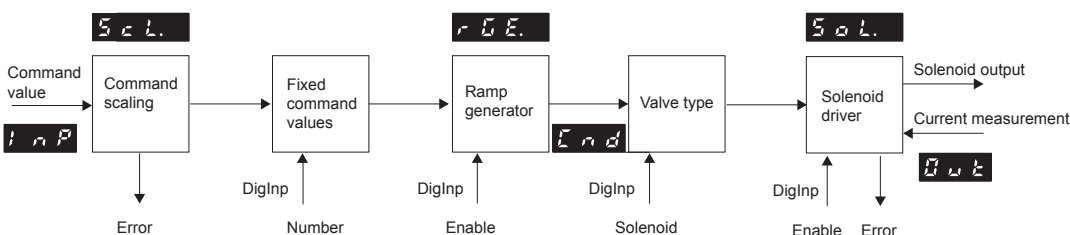

AMPLIFIER WITH ANALOGUE INTERFACE
Command value scaling

The command value can be applied as a voltage, current, digital, frequency or PWM signal. The scaling takes place via the parameter "Interface". Furthermore, the command value can be monitored for a cable break. A dead band can also be set.

Fixed command value

There is 1 fixed command value available, which can be selected via the digital input. This function has to be configured before in PASO.

Ramp generator

Two linear ramps for up and down are available which can be adjusted separately.

Valve type

Adjustment possibilities: switching solenoid or proportional solenoid.

Mode of operation „Command value unipolar/bipolar (1-Sol)

Dependent on a command value signal (voltage, current, digital, frequency or PWM), the solenoid is driven (e.g. 0...10V correspond to 0...100 % command value, 0...+100 % command value correspond to I_{min}...I_{max} solenoid driver)

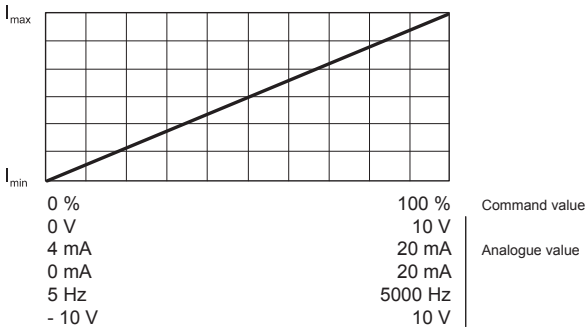
Signal recording

Furthermore, the „PD2“ amplifier electronics have a signal recording function. This, by means of PASO, enables the recording of various system signals, such as command value, solenoid current, etc., which can be represented on a common time axis.

Solenoid driver

A Pulse-Width-Modulated current output is available. A dither signal is superimposed, whereby the dither frequency and the dither level are separately adjustable. The minimum (I_{min}) and maximum (I_{max}) current can be adjusted. The solenoid output can also be configured as switching solenoid output. In this case, a power reduction can be adjusted.

Optimisation of characteristic curve

An adjustable characteristic curve „Command value input – solenoid current output“ enables an optimised (e.g. linearised) characteristic of the hydraulic system.

Channel enabling

The device is enabled as per factory setting. Via PASO or menu item, the digital input can be configured for enabling.

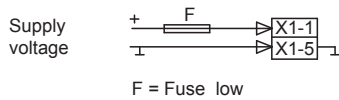
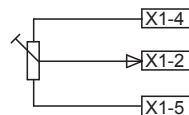
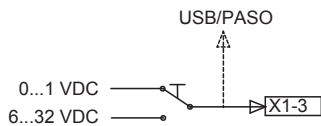
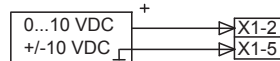
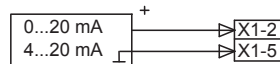
CONNECTION EXAMPLES
Supply voltage

Analogue input with potentiometer

Digital input as function input

Analogue input voltage with external voltage source

Analogue input current with external current source

Digital input as USB interface
